



TTM SHUNTOPAC® Heat recovery

Operating and maintenance instructions

TTM Shuntopac® VÅ is a shunt unit for heat recovery systems and consists of a wide range of prefabricated shunt units from DN 20 to DN 200. These can be equipped with several components of any make, in a number of different shunt couplings and always delivered pre-assembled, ready to be installed.

The brands of components included can vary on pumps and control valves, adjustment and shut-off valves.

Contact TTM Energy Products for further information regarding the shunt unit configuration.

Object:

Contract:

Site:

House / part:

ADJUSTMENT

TTM Shuntopac® U 20-50 VÅ

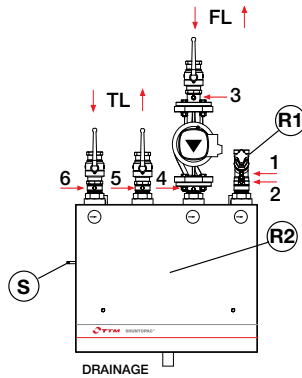

The adjustment valve **R2** is located behind the front cover.

Total flow

- Connect the differential pressure instrument to the adjustment valve **R1**. Use measuring points **1 - 2**.
- Set control valve **S** to fully open position (spindle depressed, bypass closed).
- Measure the water flow to the calculated values.

TTM Shuntopac® 65-100 VÅ

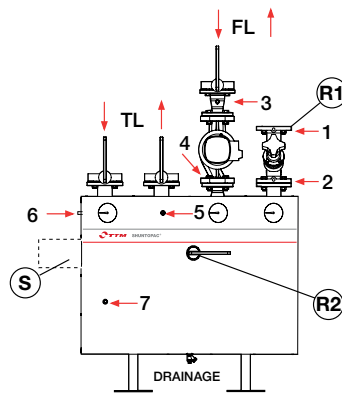

Bypass flow

- Set the control valve **S** to the fully closed position (spindle fully retracted, bypass open).
- Adjust the internal adjustment valve **R2*** until the adjustment valve **R1** obtains the same pressure drop/flow according to the calculated values.

) TTM Shuntopac® U 20-50 VÅ has the adjustment valve **R2 is located behind the front cover.*

TTM Shuntopac® 125-200 VÅ

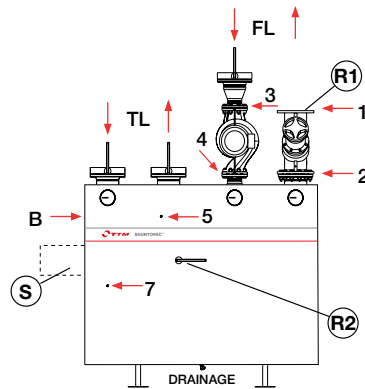

TTM Shuntopac® 20-50 VÅ

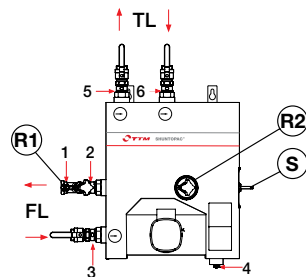

PUMPS

To ensure good heat transfer in ventilation batteries and radiator systems and to avoid freezing, a circulation pump is built into every TTM Shuntopac®. The circulation pump is an important component in the plant and requires continuous supervision.

- The circulation pump must NOT, regardless of construction, be run without the pipe system being filled with water.
- Circulation pumps, especially with wet engine, are sensitive to dirt. Therefore, ensure that the piping system is flushed before commissioning.
- Ensure that the circulation pump with 3-phase motor is connected so that the direction of rotation is correct.
- Note that the circulation pumps can be fitted with capacity control in several ways.

ARMATURE

Shut-off valves

TTM Shuntopac® is equipped with shut-off devices with connections on all pipe connections to facilitate disassembly and service. During reassembly all threads and seal faces must be lubricated with oil.

Adjustment valves - static valves

These are normally mounted in the return line. With their help, the amount of water can be adjusted and controlled with a differential pressure instrument, see adjustment instructions.

Pressure and flow regulators - dynamic valves

The differential pressure regulator is usually used together with, or instead of, static balancing valves to regulate the differential pressure across the control valve or the primary side of the shunt unit. The flow regulator is used as an automatic adjustment valve or max. flow restrictor.

Control valve

It is mounted between flange joints for easy service and interchangeability. The valve is a seating type, where the spindle has a reciprocating motion. In its end position "closed", the control cone seals metalically against a seat. To avoid costly energy losses; check that the valve motor closes properly and that dirt has not stuck to the seat.

If a 3-way control valve is used, the actuator must be mounted before filling the system.

NOTE!

For complete instructions regarding operation and maintenance of pumps and armatures, we refer to the manufacturer data sheet.

CUSTOM
SHUNT UNITS



TTM Shuntopac® Green Line

Shunt units with environmental profile and low-lead valves. Green Line is environmentally assessed at SundaHus with assessment "B" and has a rating "Accepted" by Byggvarubedömningen.

TTM Shuntopac® Green Line is a category of shunt units equipped with low-lead valves. Green Line designed specifically for customers with requirements for improved environmental assessments of SundaHus and Byggvarubedömningen. All TTM Shuntopac® shunt units are available in Green Line design. They have in general the same features and benefits as the rest of the TTM Shuntopac® shunts.

- Green Line is a product range with a focus on environmental aspects.
- Contains carefully selected components that keep levels of environmentally hazardous substances such as lead low.
- Green Line is environmentally assessed at SundaHus with assessment "B" and Byggvarubedömningen "Accepted".
- All TTM Shuntopac® shunt units can be delivered in Green Line versions.



TTM Shuntopac® EM

TTM Shuntopac® EM is shunt units equipped with energy measuring equipment of ultrasonic type according to EN 1434 class 2 and 2014/32 / EU.

Functions

The integrated energy meter registers the energy consumption in the connected control object and measured values are stored and can be read remotely.

Benefits

TTM Shuntopac® EM is a compact design and cost-effective solution when individual energy measurement is desired and comes complete with all necessary functions. TTM Shuntopac® EM is delivered as standard, with all pipe connections facing upwards.



TTM Shuntopac® Dynamic

TTM Shuntopac® Dynamic is shunt units with integrated differential pressure control and dynamic balancing.

TTM Shuntopac® Dynamic provides correct regulation in systems with variable differential pressure or when the differential pressure is unknown (see technical specifications for working area for each valve model and size). TTM Shuntopac® Dynamic is provided with a multifunction valve (PICV, combi valve) with three combined functions:

- Modulating control valve • Differential pressure regulator • Dynamic adjustment valve

Functions

- The control function regulates the flow according to the current power requirement.
- The differential pressure function takes care of pressure variations in the primary system and keeps the differential pressure constant over the control valve cone.
- The adjustment function limits the flow to the set value.

Benefits

TTM Shuntopac® Dynamic provides correct regulation in systems with variable differential pressures or when the differential pressure is unknown. TTM Shuntopac® Dynamic is delivered with the primary side adjusted to the projected flow.

This means that only the shunt unit's secondary side needs to be adjusted when the it is installed and that a check needs to be done that the available differential pressure on the primary side is within the shunt unit's working range. All TTM Shuntopac® models can be delivered in Dynamic versions.

TROUBLESHOOTING

Flow too low the primary side	Flow too low the secondary side	To high Δt between supply and return	Heat transfer when valve is closed	The temperature of outgoing heat cannot be as high as incoming hot water*
<p>Check that all valves are open.</p> <p>Check that pipes, pumps and valves not are clogged with gravel, welding slag, etc.</p> <p>Ventilate the system.</p> <p>Check that sufficient water pressure is obtained from the main pump.</p>	<p>Check that all valves are open.</p> <p>Check that pipes, pumps and valves not are clogged with gravel, welding slag, etc.</p> <p>Ventilate the system.</p> <p>Check that a sufficient pressure set is obtained from the circulation pump.</p>	<p>The power output is larger than calculated, e.g. due to too high air volume.</p> <p>Flow lower than calculated; check according to adjustment instructions.</p>	<p>With manual operation, check that the control valve closes completely.</p> <p>Check that the valve sealing surfaces are free of deposits.</p>	<p>a) The circulation pump works with too high a capacity. Return water from the secondary side is mixed in via the non-return valve line. Adjust the flow according to the adjustment instructions.</p> <p>b) The flow on the primary side is too low. Adjust the flow according to the adjustment instructions.</p>

* In some systems temperatures may vary, for example underfloor heating coils.